

Taper shank end mills

long



421940 421245

CZ Frézy válcové čelní | s MK, dlouhé, polohrubozubé

DE Schaftfräser mit MK | Lang

RU Фрезы концевые с коническим хвостовиком | длинные, среднезубые

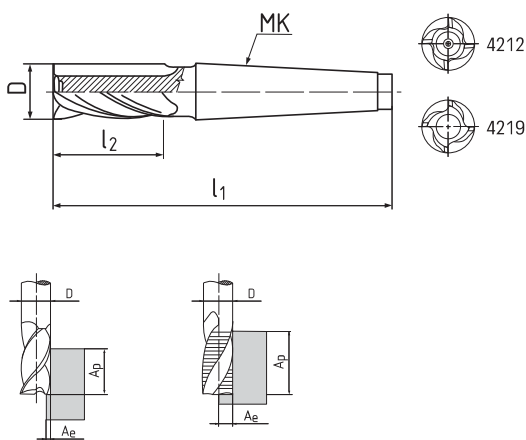

4212

4219



D k 10**	MK	l1		l2		Z	421245		421940	
		4212	4219	4212	4219					
10	1	115		45		4	.100			
12	2	138		53		4	.120			
14	2	138		53		4	.140			
16	2	148		63		4	.160			
18	2	148		63		4	.180			
20	2	160		75		4	.200			
22	2	160	160	75	75	5	.220		.220	
24	3	192		90		5	.240			
25	3	192	184	90	80	5	.250		.250*	
26	3	192		90		5	.260			
28	3	192		90		5	.280			
30	3	192		90		6	.300			
32	4	231	229	106	100	6	.320		.320*	
36	4	231		106		6	.360			
40	4	250	250	125	125	6	.400		.400	
45	4	250		125		6	.450			
50	5	308	308	150	150	6	.500		.500	
50	5		268		110	6			.500110	
56	5	308		150		8	.560			
63	5	338	338	180	180	8	.630		.630	

*) ≠ DIN 845

**) 421940 = js 14

Cutting conditions | Řežné podmínky | Schnittbedingungen | Условия резания

Material	Ap	Ae	Vc	fz (mm/z)								
				Ø 10	Ø 16	Ø 20	Ø 25	Ø 32	Ø 40	Ø 50	Ø 63	
421245												
P.1	≤ 600 N/mm²	1xD	0,1xD	37,5	0,028	0,044	0,057	0,071	0,091	0,110	0,120	0,130
P.2	≤ 850 N/mm²	1xD	0,1xD	32,5	0,028	0,044	0,057	0,071	0,091	0,110	0,120	0,130
P.3	≤ 1100 N/mm²	1xD	0,1xD	18	0,028	0,044	0,057	0,071	0,091	0,110	0,120	0,130
P.4	≤ 900 N/mm²	1xD	0,1xD	25	0,028	0,044	0,057	0,071	0,091	0,110	0,120	0,130
P.5	≤ 1100 N/mm²	1xD	0,1xD	18	0,028	0,044	0,057	0,050	0,064	0,077	0,084	0,091
P.6	> 1100 N/mm²	1xD	0,1xD	16	0,020	0,031	0,040	0,035	0,045	0,054	0,059	0,064
M.2	750 - 850 N/mm²	1xD	0,1xD	10	0,028	0,044	0,057	0,050	0,064	0,077	0,084	0,031
K.2	> 800 N/mm²	1xD	0,1xD	22	0,028	0,044	0,057	0,050	0,064	0,077	0,084	0,045
S.1	≤ 1500 N/mm²	1xD	0,1xD	8	0,020	0,031	0,040	0,035	0,045	0,054	0,059	0,022
421940												
P.1	≤ 600 N/mm²	1xD	0,1xD	37,5			0,057	0,071	0,091	0,110	0,120	0,130
P.2	≤ 850 N/mm²	1xD	0,1xD	32,5			0,057	0,071	0,091	0,110	0,120	0,130
P.4	≤ 900 N/mm²	1xD	0,1xD	25			0,057	0,071	0,091	0,110	0,120	0,130
K.1	≤ 820 N/mm²	1xD	0,1xD	25			0,057	0,071	0,091	0,110	0,120	0,130