

Half circle milling cutters

concave



820070 820075V

CZ Frézy půlkruhové | vyduté

DE Halbrund-Profilfräser | konkav

RU Фрезы полукруглые | вогнутые

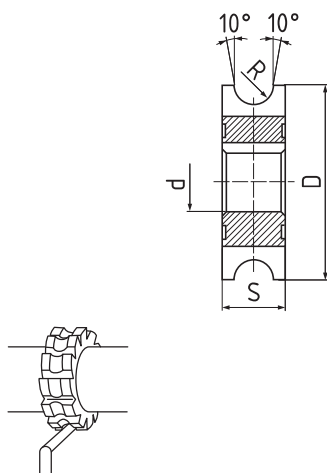

8200



8200V



D js 16	S js 16	d H 7	R	Z		820070		820075V	
				8200	8200V				
50	6	16	1	14	14	.010		.010	
50	6	16	1,25	14	14	.0125		.0125	
50	8	16	1,5		14			.015	
50	8	16	1,6	14		.016			
50	9	16	2	14	14	.020		.020	
63	10	22	2,5	12	14	.025		.025	
63	12	22	3	12	12	.030		.030	
63	12	22	3,15	12		.0315			
63	16	22	3,5	12		.035			
63	16	22	4	12	12	.040		.040	
63	18	22	4,5	12		.045			
63	20	22	5	12	10	.050		.050	
80	24	27	6	12	10	.060		.060	
80	24	27	6,3	12		.063			
80	24	27	7	12		.070			
80	32	27	8	12	10	.080		.080	
100	32	32	9	12	10	.090		.090	
100	36	32	10	12	10	.100		.100	
100	40	32	12	12	10	.120		.120	
100	40	32	12,5	12		.125			
125	50	32	16	10		.160			
125	60	32	20	10	10	.200		.200	

Cutting conditions | Řežné podmínky | Schnittbedingungen | Условия резания

Material	A _p	A _e	V _c	f _z (mm/z)						
				Ø 50	Ø 63	Ø 80	Ø 100	Ø 125		
820070										
P.1	≤ 600 N/mm ²	1xR	2xR	30	0,08	0,100	0,120	0,140	0,142	
P.4	≤ 900 N/mm ²	1xR	2xR	20	0,08	0,100	0,120	0,140	0,142	
K.1	≤ 820 N/mm ²	1xR	2xR	25	0,08	0,100	0,120	0,140	0,142	
K.2	> 800 N/mm ²	1xR	2xR	17	0,08	0,100	0,120	0,140	0,142	
820075V										
P.1	≤ 600 N/mm ²	1xR	2xR	37,5	0,080	0,100	0,120	0,140	0,142	
P.3	≤ 1100 N/mm ²	1xR	2xR	18	0,080	0,100	0,120	0,140	0,142	
P.4	≤ 900 N/mm ²	1xR	2xR	25	0,080	0,100	0,120	0,140	0,142	
P.6	> 1100 N/mm ²	1xR	2xR	16	0,056	0,070	0,084	0,098	0,0994	
M.2	750 - 850 N/mm ²	1xR	2xR	10	0,080	0,100	0,120	0,140	0,142	
K.1	≤ 820 N/mm ²	1xR	2xR	30	0,080	0,100	0,120	0,140	0,142	
K.2	> 800 N/mm ²	1xR	2xR	22	0,080	0,100	0,120	0,140	0,142	