

Single angle milling cutters



HSS

CZ Frézy úhlové | jednostranné

DE Aufsteck-Winkelfräser | einseitig

RU Фрезы угловые | осторонние

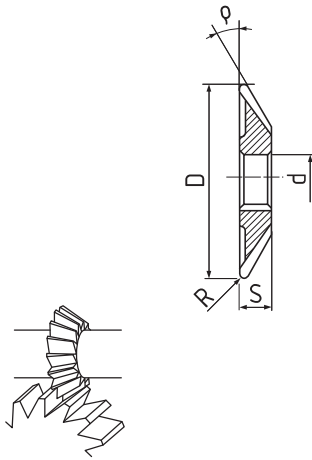

8525



ρ ± 30'	D js 16	S js 16	d H 7	R	Z	852570
20°	63	6	16	1	14	.020063
20°	100	10	27	1,5	18	.020100
25°	63	6	22	1	14	.025063
25°	80	10	22	1	16	.025080
25°	100	14	27	1,5	18	.025100
25°	125	18	27	2	20	.025125
25°	160	22	32	2,5	22	.025160
30°	63	8	22	1	14	.030063
30°	100	14	27	1,5	18	.030100

Cutting conditions | Řezné podmínky | Schnittbedingungen | Условия резания

Material	A _p	A _e	V _c	f _z (mm/z)				
				Ø 63	Ø 80	Ø 100	Ø 125	Ø 160
P.1 ≤ 600 N/mm ²		1xS	30	0,035	0,040	0,043	0,048	0,052
P.4 ≤ 900 N/mm ²		1xS	20	0,035	0,040	0,043	0,048	0,052
K.1 ≤ 820 N/mm ²		1xS	25	0,035	0,040	0,043	0,048	0,052
K.2 > 800 N/mm ²		1xS	17	0,035	0,040	0,043	0,048	0,052
N.4 ≤ 800 N/mm ²		1xS	50–90	0,035	0,040	0,043	0,048	0,052