

ČSN 22 3010

NO/CS/WS
code 110 XXX

HSS
code 140 XXX

NO/CS/WS-LH
code 120 XXX

HSS-LH
code 150 XXX

Závitníky sadové Set of hand taps Satzgewindebohrer Метчики наборные

M
Metrický závit
Standard metric thread
Metrische Regelgewinde
Метрическая резьба

MF
Jemný metrický závit
Fine metric thread
Metrische Feingewinde
Мелкая метрическая резьба

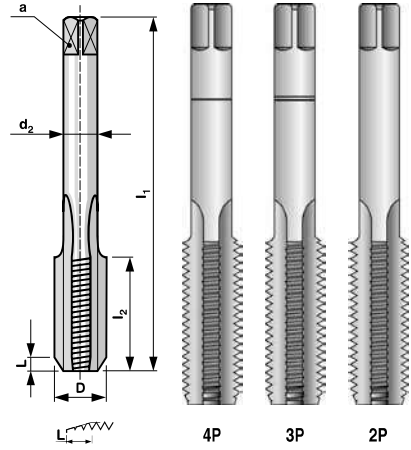
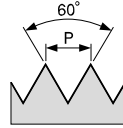
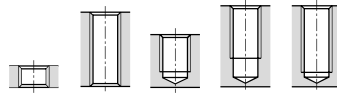

Lícování: 2N / Tolerance: 2N /
Toleranz: 2N / Подгонка: 2N

D	P	l ₁	l ₂	d ₂	a		*	code NO/CS/WS	code HSS	code NO/CS/WS - LH	code HSS - LH
M 2	0,4	34	8	2,5	2	1,60	3	110 020	140 020	120 020	150 020
M 2,2	0,45	34	9	2,8	2,24	1,75	3	110 022	140 022		
M 2,5	0,45	34	10	2,8	2,24	2,05	3	110 025	140 025		
M 2,5	0,35	28	8	2,8	2,24	2,15	2	110 026	140 026		
M 3	0,5	36	10	3,15	2,5	2,50	3	110 030	140 030	120 030	150 030
M 3	0,35	32	8	3,15	2,5	2,65	2	110 031	140 031		
M 3,5	0,6	36	12	3,55	2,8	2,90	3	110 035	140 035		
M 3,5	0,35	32	9	3,55	2,8	3,15	2	110 036	140 036		
M 4	0,7	41	14	4	3,15	3,30	3	110 040	140 040	120 040	150 040
M 4	0,5	38	11	4	3,15	3,50	2	110 041	140 041		
M 4,5	0,5	38	11	4,5	3,55	4,00	2	110 046	140 046		
M 5	0,8	45	16	5	4	4,20	3	110 050	140 050	120 050	150 050
M 5	0,5	40	11	5	4	4,50	2	110 051	140 051		
M 5,5	0,5	40	12	5,6	4,5	5,00	2	110 056	140 056		
M 6	1	50	17	4,5	3,55	5,00	3	110 060	140 060	120 060	150 060
M 6	0,75	44	15	4,5	3,55	5,20	2	110 061	140 061		
M 7	1	50	17	5,6	4,5	6,00	3	110 070	140 070	120 070	150 070
M 7	0,75	44	15	5,6	4,5	6,20	2	110 071	140 071		
M 8	1,25	54	22	6	5	6,80	3	110 080	140 080	120 080	150 080
M 8	1	46	16	6	5	7,00	2	110 081	140 081		
M 8	0,75	44	16	6	5	7,20	2	110 082	140 082		
M 9	1,25	60	22	7,1	5,6	7,80	3	110 090	140 090	120 090	150 090
M 9	1	52	17	7,1	5,6	8,00	2	110 091	140 091		
M 9	0,75	50	17	7,1	5,6	8,20	2	110 092	140 092		
M 10	1,5	63	25	7,1	5,6	8,50	3	110 100	140 100	120 100	150 100
M 10	1,25	56	18	7,1	5,6	8,80	2	110 101	140 101		
M 10	1	56	18	7,1	5,6	9,00	2	110 102	140 102		
M 10	0,75	56	18	7,1	5,6	9,20	2	110 103	140 103		
M 11	1,5	63	28	8	6,3	9,50	3	110 110	140 110	120 110	150 110
M 11	1	56	20	8	6,3	10,00	2	110 111	140 111		
M 11	0,75	56	20	8	6,3	10,20	2	110 112	140 112		
M 12	1,75	70	30	9	7,1	10,20	3	110 120	140 120	120 120	150 120
M 12	1,5	63	25	9	7,1	10,50	2	110 121	140 121		
M 12	1,25	60	22	9	7,1	10,80	2	110 122	140 122		
M 12	1	60	22	9	7,1	11,00	2	110 123	140 123		
M 14	2	80	30	11	9	12,00	3	110 140	140 140	120 140	150 140
M 14	1,5	70	28	11	9	12,50	2	110 141	140 141		
M 14	1,25	63	25	11	9	12,80	2	110 142	140 142		
M 14	1	63	25	11	9	13,00	2	110 143	140 143		
M 15	1	70	25	11	9	14,00	2	110 152	140 152		
M 16	2	80	35	12,5	10	14,00	3	110 160	140 160	120 160	150 160
M 16	1,5	70	28	12,5	10	14,50	2	110 161	140 161		
M 16	1	70	25	12,5	10	15,00	2	110 162	140 162		
M 17	1	70	28	12,5	10	16,00	2	110 171	140 171		
M 18	2,5	90	36	14	11,2	15,50	3	110 180	140 180	120 180	150 180
M 18	1,5	80	32	14	11,2	16,50	2	110 181	140 181		
M 18	1	70	28	14	11,2	17,00	2	110 182	140 182		
M 20	2,5	90	36	14	11,2	17,50	3	110 200	140 200	120 200	150 200
M 20	1,5	80	32	14	11,2	18,50	2	110 201	140 201		
M 20	1	75	28	14	11,2	19,00	2	110 202	140 202		
M 22	2,5	90	40	16	12,5	19,50	3	110 220	140 220	120 220	150 220
M 22	1,5	80	32	16	12,5	20,50	2	110 221	140 221		
M 22	1	75	28	16	12,5	21,00	2	110 222	140 222		
M 24	3	100	45	18	14	21,00	3	110 240	140 240	120 240	150 240
M 24	2	90	36	18	14	22,00	2	110 241	140 241		
M 24	1,5	85	32	18	14	22,50	2	110 242	140 242		
M 24	1	80	28	18	14	23,00	1	110 243	140 243		
M 25	1,5	90	32	18	14	23,50	2	110 252	140 252		
M 26	1,5	90	32	18	14	24,50	2	110 262	140 262		
M 27	3	100	45	20	16	24,00	3	110 270	140 270	120 270	150 270



BUČOVICE
TOOLS a.s.

Materiál: NO; HSS
Provedení: nebroušený závit
Závit: pravý,
levý - dle požadavku

Material: CS-carbon steel;
HSS
Execution: non-ground thread
Thread: right-hand, left-hand
on request

Werkstoff: WS-Werkzeugstahl;
HSS
Ausführung: nicht
geschliffenes Gewinde
Gewinde: rechts, links - nach
dem Anspruch

Материал: NO-инстру-
ментальная сталь; HSS
Изготовлено:
нешлифованная резьба
Резьба: правая,
левая - по заказу

ČSN 22 3010

NO/CS/WS
code 110 XXX

HSS
code 140 XXX

NO/CS/WS-LH
code 120 XXX

HSS-LH
code 150 XXX

Závitníky sadové Set of hand taps Satzgewindebohrer Метчики наборные

M
Metrický závit
Standard metric thread
Metrische Regelgewinde
Метрическая резьба

MF
Jemný metrický závit
Fine metric thread
Metrische Feingewinde
Мелкая метрическая резьба

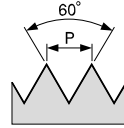
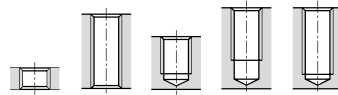

Lícování: 2N / Tolerance: 2N /
Toleranz: 2N / Подгонка: 2N

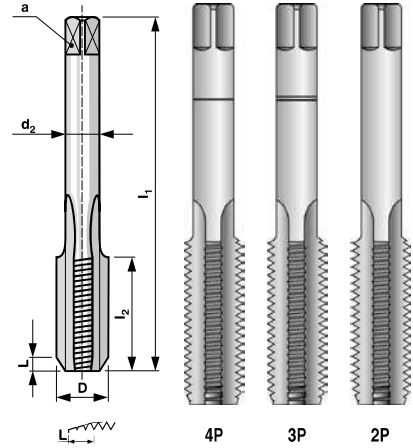

D	P	l ₁	l ₂	d ₂	a		*	code NO/CS/WS	code HSS	code NO/CS/WS - LH	code HSS - LH
M 27	2	90	36	20	16	25,00	2	110 271	140 271		
M 27	1,5	90	32	20	16	25,50	2	110 272	140 272		
M 27	1	85	28	20	16	26,00	1	110 273	140 273		
M 28	2	100	36	20	16	26,00	2	110 281	140 281		
M 28	1,5	90	32	20	16	26,50	2	110 282	140 282		
M 30	3,5	120	50	20	16	26,50	3	110 300	140 300		
M 30	2	100	36	20	16	28,00	2	110 301	140 301		
M 30	1,5	100	32	20	16	28,50	2	110 302	140 302		
M 30	1	85	32	20	16	29,00	1	110 303	140 303		

* kusy v sadě / pcs in set / Stk in Satz / штук в наборе

Materiál: NO: HSS
Provedení: nebroušený závit
Závit: pravý,
levý - dle požadavku

Material: CS-carbon steel;
HSS
Execution: non-ground thread
Thread: right-hand, left-hand
on request

Werkstoff: WS-Werkzeugstahl;
HSS
Ausführung: nicht
geschliffenes Gewinde
Gewinde: rechts, links - nach
dem Anspruch

Material: NO-инструмен-
тальная сталь; HSS
Изготовлено:
нешлифованная резьба
Резьба: правая,
левая - по заказу

BUČOVICE
TOOLS a.s.

M / MF